

ATTACHMENTS & ACCESSORIES

1. **Hoof Polisher & Silver Polisher:** Optional handpiece #504HP replaces clipper handpiece on cable to allow for easy hoof sanding and polishing. Sanding disks are available in fine, med and coarse. Cotton polishing wheel is available for leather and silver.

2. **General purpose handpiece:** Optional handpiece #503 replaces clipper handpiece on cable to be used for sectioning teeth with diamond or carbide saw blades or grinding nails and beaks.

3. **Orthopedic handpiece:** Optional handpiece #504 replaces clipper handpiece on cable to allow for easy drilling and pinning during orthopedic procedures. Autoclavable. Accepts bits and pins up to 5/32" diameter.

4. **Dental attachment accessories:** #101 polishing tips and #102 paste cups.

5. **The Blade Caddy:** #10362 for storage and cleaning of blades and accessories.



#584 - Hoof Polisher
Fine, Med, Coarse

#504 - Orthopedic
Handpiece



#504 - Orthopedic
Handpiece



#560 - Grinding
Stone

#503 - General
Purpose
Handpiece



The Blade Caddy
#10362



#101 - Polishing
Tip



#102 - Paste
Cups

DOUBLE
INDUSTRIES

The Professional
GROOMER'S
EDGE®

401
Power Clipper



INSTRUCTION MANUAL

**PLEASE READ ALL INSTRUCTIONS AND SAFETY
PRECAUTIONS BEFORE OPERATING PRODUCT!**

**SAVE FOR FUTURE REFERENCE; WARRANTY
PERTINENT CONTENT.**

Product Specifications: Model - 401 Power Clipper

Belt-Mounted
Voltage: 115v
Amperage: .8
Wattage: 92
Horsepower: 1/12

Portable
Voltage: 115v
Amperage: .8
Wattage: 92
Horsepower: 1/12

9711 Mason Avenue, Chatsworth, CA 91311
(818) 772-2887 • (800) 821-9449 • fax: (818) 886-0218
www.DoubleKIndustries.com • info@DoubleKIndustries.com

IMPORTANT SAFEGUARDS

WARNING: IMPORTANT SAFETY PRECAUTIONS!! PLEASE READ COMPLETELY BEFORE USING PRODUCT!!

When using electrical appliances, especially in the presence of children and animals, basic safety precautions should always be followed to reduce the risk of fire, electric shock, and personal injury, including but not limited to the following:

1. Do not expose equipment to water or rain.
2. Do not operate while standing in water.
3. Unplug unit when not in use or before attempting any maintenance or service.
4. Do not unplug unit by pulling on cord. Do not operate with a damaged cord or plug.
5. Recommended operation by adults only. Use caution when working around children.
6. Do not use attachments not recommended by the manufacturer.
7. Plug only into a properly grounded outlet.
8. Do not attempt to perform any service or maintenance not outlined in this manual. Contact **Double K Industries** or an authorized service center if additional service is required.
9. Check blades periodically for heat buildup & rotate as necessary to prevent skin burn.
10. Avoid direct contact with moving blades.
11. Never use blades with broken or chipped teeth.
12. When servicing, use only **Double K** parts.

OPERATION

Notice: Before operation of clipper, make sure the mechanical cable is laid out and not in a coil. If clipper is operated with cable in a coiled radius the cable may break or become damaged.

SWITCHES AND CONTROLS:

Turn control knob clockwise to turn clipper on. Continue turning knob counterclockwise to increase speed. Turn back counterclockwise completely to turn clipper off. (fig.1)

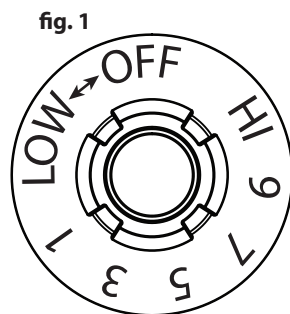

HANDPIECE MAINTENANCE - DURING GROOMING SEASON:

At least once a month remove cover plate and blade lever so that all collected hair can be brushed out. (fig. 2) Be careful not to displace the felt pads that are located next to the lever. Lubricate the hole and cut out notch in the back of the lever with all-purpose grease. While the blade lever is removed, place a dab of grease on the front of the lever bearing which is located on the front of the flywheel. (fig.3) Re-install the blade lever being sure the lever bearing on the flywheel fits into the cutout notch in the rear of the lever. Clean and replace the cover plate. Tighten screws snugly. Spread thin film of grease on top of lever where blade is contacted.

To remove Handpiece from cable (fig. 8 page 7)- Hold handpiece firmly in one hand, cable in the other and pull apart sharply. To replace handpiece on cable- Hold cable with tip pointing up. Set handpiece on cable making sure cable enters handpiece straight and NOT at an angle. Gently rotate handpiece until the cable tip "key" aligns with the "key way" in the handpiece and handpiece drops slightly into cable. Then push up on cable to lock into place.

TROUBLESHOOTING:

Problem: Clipper or blades are clattering or noisy, or clipper is not cutting as fast as before, leaving rows or tracks on animal.

Solution: The blade lever may be worn and should be checked. Perform the following tests to check for lever wear. With the handpiece connected to the drive cable and the blade removed, visually inspect the top front part of the lever. It should not be "chewed" or have cuts or gashes on the sides. If it does, replace as described below. Then grasp the exposed end of the blade lever between thumb and forefinger and try to wiggle from side to side. Lever should feel firm with no "play". If "play" exists, lever should be replaced.

CABLE MAINTENANCE:

Once a year or after storage or extended non-use, the flex cable should be lubricated.

Step 1 - To remove cable from motor (fig 7), loosen allen set screws on top of motor housing "snout" which hold cable in place. Remove cable by pulling straight out. To remove cable from handpiece, (fig 8) simply pull cable away sharply from handpiece. **Step 2** - Remove inner spring cable from outer rubber casing by removing the snap ring and washer from one end of the cable with pliers. From opposite end, pull inner cable out of rubber casing. **Step 3** - Using any all purpose grease, lightly coat the spring cable from end to end. **Step 4** - Slide spring inner cable back into rubber casing and replace washer and snap ring. **Step 5** - Replace cable into the motor housing by aligning the cable tip with the key way in the motor "snout" and tighten allen set screws securely.

WARNING - Please use caution to prevent breakage of flex shaft. Do not make extreme bends. To prevent cable breakage or damage, do not hang cable on hook, nail or wire. Models with cables longer than 7' have cable hangers included. Models with cables over 10' should not be operated with the cables wound tightly but rather with the flex shaft extended.

Replacing Flex Cable: (fig 7)

Step 1: Remove clipper handpiece and set aside. (See section on detaching handpieces.) Remove old cable by loosening the two allen set screws located in the nose portion of the motor housing, 180 degrees apart. (not the Philips head screws)

Step 2: Proceed by aligning the cable tip into the keyway in the motor housing and retighten both allen set screws. Be careful not to insert the cable tip at an angle as it could damage the tip.

Step 3: Straighten out the cable and turn on the motor to make sure the inner cable is turning properly. Now turn off motor and tighten set screws. Re-attach handpiece.

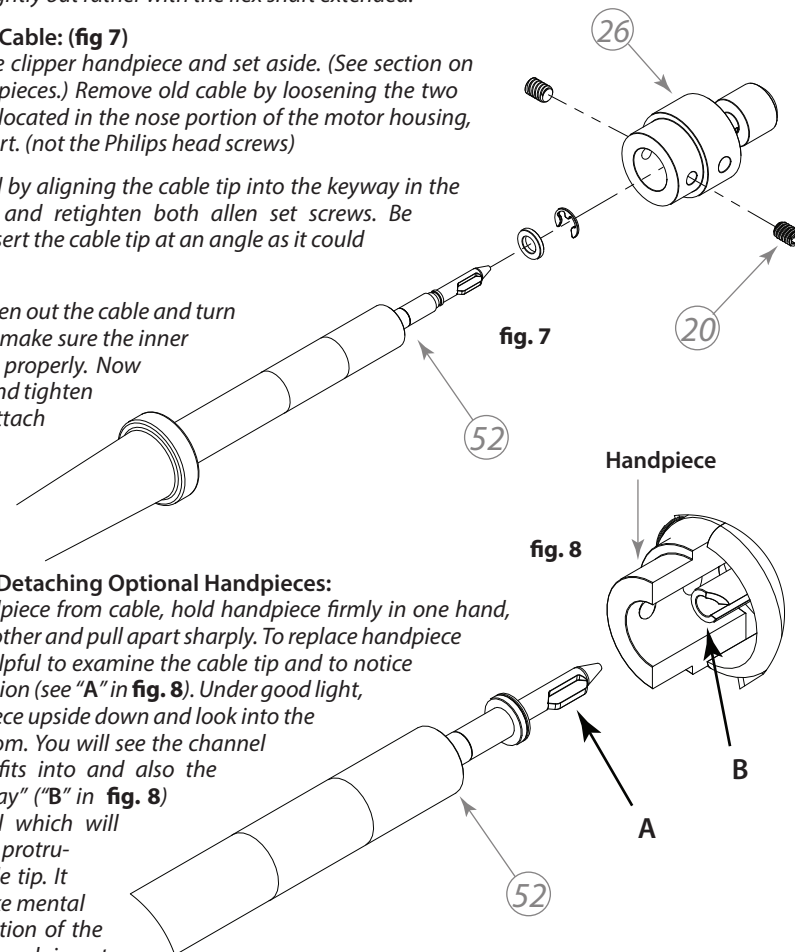

Attaching and Detaching Optional Handpieces:

To remove handpiece from cable, hold handpiece firmly in one hand, the cable in the other and pull apart sharply. To replace handpiece on cable, it is helpful to examine the cable tip and to notice the "key" protrusion (see "A" in fig. 8). Under good light, turn the handpiece upside down and look into the hole in the bottom. You will see the channel that the cable fits into and also the cutout or "keyway" ("B" in fig. 8) in that channel which will receive the key protrusion on the cable tip. It is helpful to make mental note of the position of the cutout in the handpiece to help line up the cable tip "key" properly when attaching the handpiece. Now hold the cable with tip pointing up. Set handpiece on cable making sure cable enters handpiece straight and not at an angle. Gently rotate handpiece until the cable tip "key" aligns with the "keyway" in the handpiece and the handpiece drops slightly onto the cable. Then push up in the cable to lock into place.

Storage: See "Maintenance section-cable" for instructions if hanging cable. Follow lubrication procedure for cable under same section before re-use after lengthy storage.

ATTACHING AND CHANGING BLADES:

Select desired A-5 blade or equivalent and set directly on open hinge. The hinge should slide into the slot at the bottom of the blade. If hinge has snapped closed without the blade, use a flat blade screwdriver to open then attach blade. (fig. 4) With clipper running on low speed, snap blade down against clipper housing to engage blade. To remove blade, press up on blade release with thumb and pull blade back to disengage. (fig. 5)

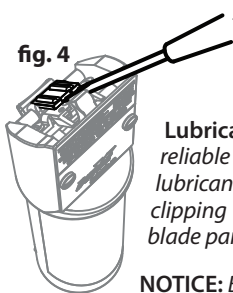

fig. 4

Lubricant: It is essential to use a proper lubricant on your blades to insure long reliable service and smooth professional results. We recommend a Teflon based lubricant purchased at your local hardware store. Lubricate the blade often during clipping by turning the blade to the side and lubricating at the points where the two blade parts make contact. Lubricate sparingly and wipe away any excess.

NOTICE: Be careful not to let excess lubricant run down into the clipper handpiece as it could damage the clipper bearings. **Please note:** lubricant and blade wash are not the same. A lubricant allows the blades to operate smoothly and reduces friction to delay blade heat-up. Blade wash or coolant simply cleans and cools hot blades, but provides very little, if any lubrication.

All blades will eventually get hot during use. Therefore, we suggest that you rotate several sets of blades allowing the hot blades to soak in a coolant or blade wash until cool while continuing to clip with fresh, cool blades. Always lubricate before re-use. (For blades that heat-up very quickly, see section on Blade Tension)

Please read the section on **BLADE MAINTENANCE** below before using clipper.

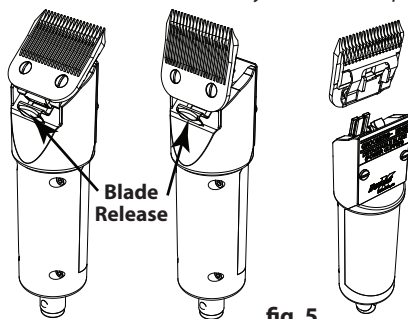

fig. 5

BLADE MAINTENANCE:

Using new blades - Some new blades are coated with a sticky film to protect the blades from moisture during shipping and storage. This coating must be removed before the first use by soaking the blade in blade wash or similar solvent. After removal of the coating, wipe dry with paper towel and lubricate proper points. (see section on lubricant under operation).

Blade Tension (fig 6) - It is important to maintain proper blade tension to guard against excessive heat build-up in the blades during use. To check for proper tension, hold the blade so the spring clip faces you. Using both thumbs (and with blade clean and lubricated) slide the cutter back and forth. You should be able to move the cutter without a lot of effort. If the cutter is very tight and difficult to move, the blades will heat up prematurely, and the tension should be loosened. However, if the cutter moves too freely, hair and debris could become jammed between blade parts, causing the blades to stop cutting suddenly. Tighten tension as described herein. Please note that the screws holding the spring clip in place should always be tight and are not a means of adjusting tension.

To Loosen Blade Tension - Insert a flat blade screwdriver under one side of spring clip (the clip that holds the two blade components together) and twist the screwdriver so as to pry the clip up slightly. Repeat on other side of spring clip. Re-check tension using testing method above.

To Tighten Blade Tension - Blades must be disassembled by removing the two screws holding the spring clip in place. Take a pair of pliers and gently grasp the very bottom of the spring clip. Squeeze gently. Repeat on other side of spring clip. Re-assemble blade and re-check tension using testing method above.

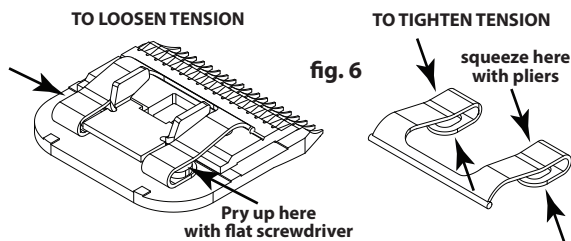

fig. 6

Any maintenance not explained in this manual should be performed by Double K Industries or an authorized service center. Call Double K Industries for the name of the service center nearest you. All warranty service MUST be performed by an authorized service center to protect warranty status.

LEVER REPLACEMENT

To replace the lever: Remove screws in the clipper faceplate; remove old lever and install new lever on the post. Be sure to place a small amount of all-purpose grease on the lever post and in the back of the notched groove of the lever before installing. Replace faceplate and tighten faceplate screws securely.

1. Check the clipper latch: Remove blade and inspect the latch hook (the latch is the small black metal component located beneath the hinge which is pushed by the thumb when removing and installing blades). The upper end of the latch has a small hook. By turning the clipper to the side and examining the top of the latch, a small "C" shaped hook should be seen. If the hook is broken the latch should be replaced. **To Replace the Latch:** Loosen the two screws holding the latch and hinge assembly in place. Remove the latch and hinge assembly. Remove broken latch up and away from hinge and release small spring hooks holding the components together. Place the spring hooks on the hinge into the holes of the new latch and push the new latch into the proper position on the hinge. Re-install latch and hinge assembly on the clipper handpiece using removable "loctite" on screw threads.

2. Check metal hinge stabilizers on the blade. With the blade removed from the clipper handpiece, hold the blade in hand with the moving portion of the blade (the cutter) facing you. Observe the metal spring clip which holds the cutter to the stationary portion of the blade (the comb). The spring clip has two metal protrusions attached to either side of the cut-out mid-section (fig. 2) which stabilizes the blade to the latch and hinge assembly during use. If these protrusions are too far apart, the blade is not stable during clipping and therefore will chatter during use.

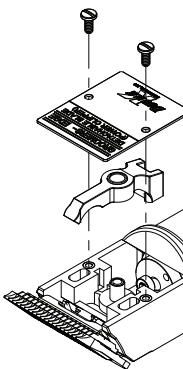

fig. 2

stabilizers

To Stabilize Blade: Take a pair of pliers and squeeze together slightly the metal protrusions on the blade spring clip. Test blade on clipper handpiece to see if blade runs quietly. If blade is still noisy, remove blade and squeeze the metal protrusions again.

***NOTE:** If stabilizers are squeezed together too closely, the blade will not seat properly on the clipper handpiece in which case they will need to be spread apart slightly.

PROBLEM: BLADES HEAT UP TOO QUICKLY:

Note: The 401 Power Clipper operates with a blade speed and range of motion that enables it to clip more effectively than any clipper in its category. This does, however, cause the blade to heat up faster than other clippers when operated at higher speed settings. Consequently, when using the highest speed settings, the blades should be rotated or sprayed with coolant more frequently.

Valuable techniques for reducing blade heat:

- 1. Turn down the speed.** If blades are heating up too quickly, use a lower speed setting. The Power Clipper is still very effective at lower speeds due to the greater range of blade motion and motor power.
- 2. Wash blades in blade wash** to remove dirt or debris. ***NOTE:** Some new blades come with a sticky protective coating, which must be removed before use. Soak new blades in blade wash or similar solvent, then dry, and apply proper lubricant. Blades will get hot and must be rotated or cooled with coolant.
- 3. Use proper lubrication.** Your blades are operating at higher speeds than other clippers and need a superior lubricant. We recommend a Teflon-based lubricant like Tri-Flow from your hardware store, gun and tackle shop or bicycle shop. Lubricant should be applied at the sides of the blades where the two blade rails rub together, not in the teeth which could cause dirt and hair to clog the blade.
- 4. Check blade tension:** The comb and cutter portions of the blade should slide back and forth across each other firmly but freely. If tension is too tight, blades will overheat rapidly. If tension is too loose, blades will quit clipping suddenly and drag, as hair and dirt will jam in between the comb and the cutter. **To adjust tension, see section on "Blade Tension" under "Blade Maintenance."**

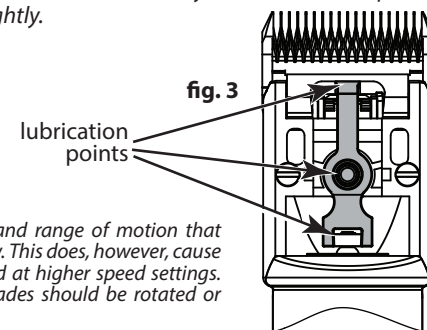
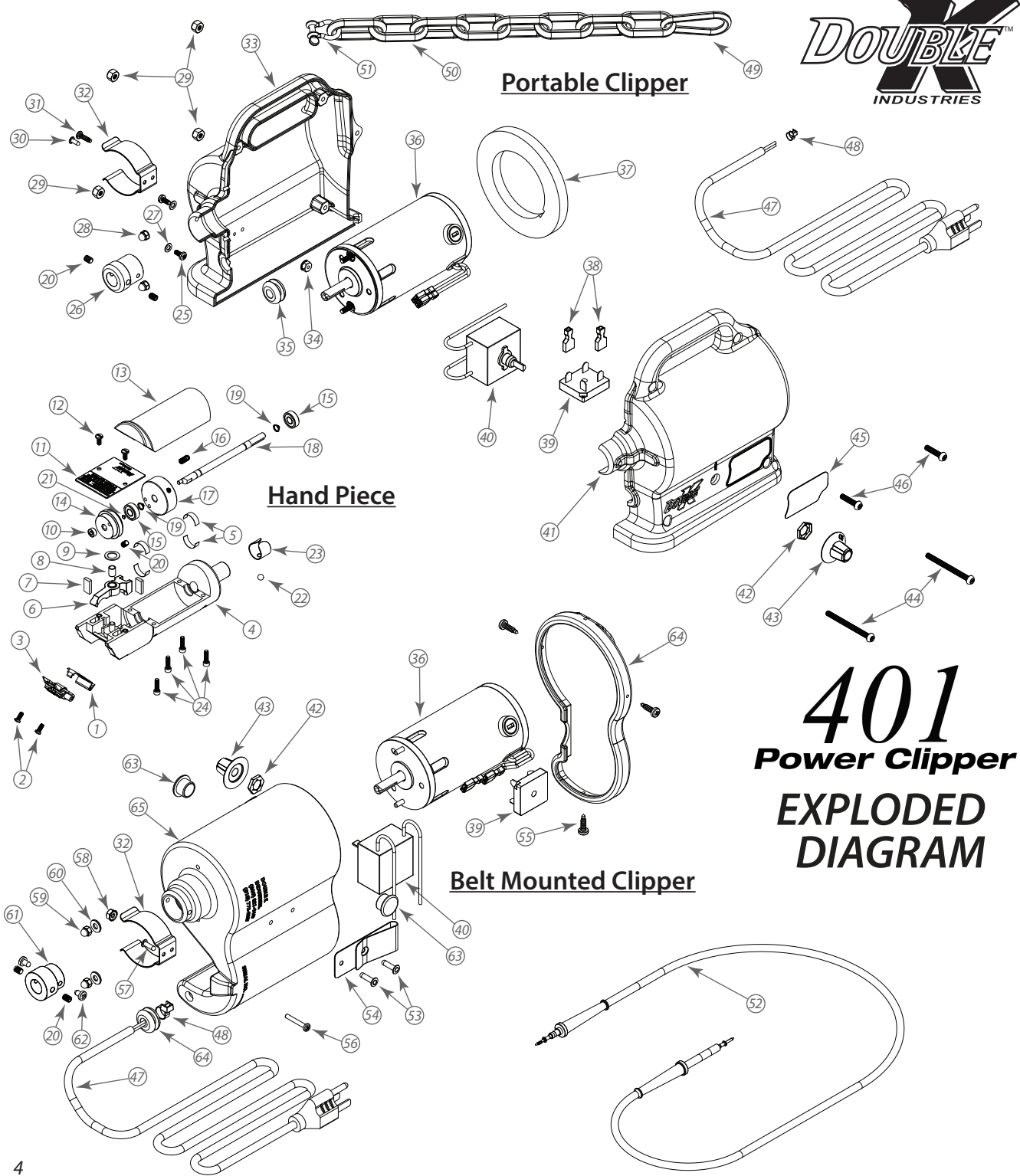

fig. 3

lubrication points



401 Power Clipper EXPLODED DIAGRAM

ITEM #	PART #	DESCRIPTION	QTY.
1	3025	Latch, Double K Clipper	1
2	444	Screw, 401, Hinge & Latch	2
3	3026	Hinge, Double K Clipper	1
4	512	Bottom Hand Piece Assy.	1
5	10307	Tape Duct	4
6	598	Drive Lever w/Bushing	1
7	508	Felts Clipper Hand Piece	2
8	431	Bushing 1/4" OD, Delrin Lever	1
9	480	Washer, Delrin .266 ID x .562	1
10	506	Lever Ball Bearing .125 ID	1
11	502	Clipper Hand Piece Cover Plate	1
12	501	Screw, 401 - Cover Plate	2
13	517	Top Clipper Hand Piece Assy.	1
14	591	Fly Wheel (Small) 500-HP	1
15	505	Shaft Bearing .25 ID	2
16	411	Screw Set #10-24 x .50 SHCP	1
17	592	Fly Wheel (Large) 500-HP	1
18	516	Shaft, Lever Drive (500-HP)	1
19	409	Retaining Ring Type "SH" .250	2
20	422	Screw Set #10-24 UNF x .25	3
21	507	Retaining Ring Type "SH" .125	1
22	515	Ball Bearing 7/32" Chrome Steel	1
23	514	Clamp, Ball Spring Black 401	1
24	513	Screw #6-32 UNF x .50 SHCS	4
25	493	Screw, 401-Motor Housing Adaptor	2
26	445	Adaptor 401 Housing Cable	1
27	490	Washer, 401 Clipper Housing	4
28	479	Nut, M4 Acorn	2
29	10078	Nut #8-32 Nylon Insert	4
30	2091	Rivet Aluminum 3/8 x 1/8"	1
31	10019	Screw #6-32 UNF x 1/2 PHP	1
32	418	Spring Clip HP	1
33	482	401-Clipper Housing (Right)	1
34	5533	Nut, #6-32 UNF Keeps Locking	1
35	534	Cord Grommet	1
36	423	401-Clipper Motor w/Wire	1
37	488	Foam Motor Support (401)	1
38	5540	Terminal 1/4" Female 22-16	4
39	9042	Rectifier AC to DC Bridge	1
40	447-1	401, 501 & 550 Speed Control	1
41	481	401-Clipper Housing (Left)	1
42	5517	Nut Hex 3/8-24 SM Self-Tap	1
43	402	Knob Rotary "Off/Low-Hi"	1
44	484	8-32 x 2" Machine Screw	2
45	494	Decal, 401-Power Clipper	1
46	485	8-32 x 3/4" Machine Screw	2
47	537	Power Cordset 120v w/Ground	1
48	426	7" 18lb. Natural Nylon Cable	1
49	575	Safety Hook, 2-3/8" x 1/4"	1
50	442	Clipper Chain 8-Links	1
51	483	Bow Shackle 316 Stainless	1
52	545-05	Assembly, 5-ft Power Cable	1
	545-06	Assembly, 6-ft Power Cable	
	545-07	Assembly, 7-ft Power Cable	
	545-10	Assembly, 10-ft Power Cable	
	545-12	Assembly, 12-ft Power Cable	
	545-15	Assembly, 15-ft Power Cable	
545-20	Assembly, 20-ft Power Cable		
53	438	Rivet Dome Pop 5/16 x 1/2	2
54	414	Belt Spring Clip	1
55	5546	Screw #8 x .63 SM	3
56	417	Screw #6-32 x 7/8" PHP	1
57	424	Rivet Dome Pop 1/8 x 3/8	1
58	5533	Nut #6-32 UHF Keeps Locking	1
59	479	Nut, M4 Acorn	2
60	9028	Washer #8 SAE Flat Plated	2
61	421	Adaptor 401-501 Housing Cable	2
62	443	Modified Screw #8 x 3/8 Sht Metal PHP	2
63	413	855 Housing Plug	2
64	534	Grommet Black	1
65	416-1	BMC Housing Assembly	1

