

















## Attachment List

For both Portable and Stand Models

Attachment	P/N	Description	Qty.
	825-6, 825-8	Hose 1½" Black on Blue	2
	2079	1½" Airgonomic Nozzle Body	1
	2079-LH	Nozzle Handle	1
	2079-TAS	Air Sweep Nozzle Tip	1
	2079-THV	Hi-Velocity Nozzle Tip	1
	2079-TSHV	Super Hi-Velocity Nozzle Tip	1
	894	1½" Hose End (Air Diffuser)	1
	802	2½" Air Diffuser	1
<i>For Stand Models Only</i>			
	890	Arm Extension Nozzle	1
	5523	Hose Clamp for Arm Ext. Nozzle	1
	892	Arm Extension	1
	555	Knobs for Arm Extension	2
	849	Knobs, 850 Y-Bar to Housing	2
	887A	Mounting Fork, 850 Y-Bar	1
	7037	Inner & Outer Tube Assembly	1
	9023	Stand Base (without casters)	1
	7064	Caster 3.5" Rubber Wheel	3
	7063	Caster 3.5" Rubber Locking Wheel	2

### ACCESSORIES AND ATTACHMENTS

Your dryer is equipped with twist-on hoses and the Airgonomic® Nozzle Kit. To attach hoses to dryer, place hose into air outlet and twist counter-clockwise. To attach Airgonomic Nozzle Body to the hose, twist the nozzle counter-clockwise. To attach Airgonomic Nozzle Tips, push tips onto the Airgonomic Nozzle Body from a slight angle.

**Cage Diffuser Attachment:** This attachment is used for diffusing air into the animal's cage. To attach the hose to the diffuser, attach the hose adapter to the hose by twisting it counter-clockwise. Then insert the adapter into diffuser.

# DOUBLE K INDUSTRIES CHALLENGAIR®



# 850

Stand & Portable Models  
**ANIMAL DRYER**



## INSTRUCTION MANUAL

PLEASE READ ALL INSTRUCTIONS AND SAFETY PRECAUTIONS BEFORE OPERATING PRODUCT. SAVE FOR FUTURE REFERENCE; WARRANTY PERTINENT CONTENT.

### Product Specifications: Model – 850

Model	850	850-XL	850 - 230v
Voltage	115	115	230
Amps	12.98	17.72	10.32
Watts	1493	2038	2374
Air Volume (Combined Motor Specs)	204 CFM	248 CFM	248 CFM



9711 Mason Avenue, Chatsworth, CA 91311  
(818) 772-2887 • (800) 821-9449 • fax: (818) 886-0218  
DoubleKIndustries.com • info@DoubleKIndustries.com

**CONGRATULATIONS!** on your purchase of the **Double K Challengair 850/850-XL Forced Air Dryer**. The Double K Challengair 850 and 850-XL Dryers produce high-velocity warm air under pressure to make your grooming tasks easier. Your new dryer is designed to provide long, reliable service.

The 850 and 850-XL are available in both stand and portable models. The stand model is equipped with a grooming arm for use during table drying. The 850-XL model produces 15% more air than the 850. Both are available with a variable speed option for greater air flow control.

Please read this manual carefully and completely before beginning operation of your dryer and keep in a convenient and safe place for future reference. A warranty card is included with your dryer and should be filled out completely and mailed to **Double K Industries** within 30 days of the purchase date of your dryer to validate your warranty. Online registration is available at [DoubleKIndustries.com](http://DoubleKIndustries.com).

Your 850/850-XL Challengair Dryer has two brush-type motors (Both models have two motors). It is important that the brushes be changed when they become worn down to prevent damage to your dryer motors (Replacing brushes are a maintenance requirement not covered under warranty). We suggest checking the motor brushes after every 600 hours of dryer use. Please see section called "Maintenance - Brushes" on p.6 in this manual for instructions.

## IMPORTANT SAFEGUARDS

DO NOT TURN ON DRYER WITHOUT FIRST HOLDING THE DRYER HOSE as the air volume from the dryer can cause the hose to move and swirl and may cause injury.

- Do not leave dryer OR animal unattended while in use.
- Unplug unit when not in use.
- Do not use extension cords with dryer.
- Do not unplug by pulling on cord.
- Do not expose dryer to rain or water.
- Do not use or store where dryer can fall or be pulled into tub, sink or standing water. If dryer falls into water...**UNPLUG IT...DO NOT REACH INTO THE WATER!**
- Unplug unit before attempting any service or maintenance.
- Do not put any object into dryer openings.
- Keep loose clothing, jewelry and hair away from dryer openings.
- Do not direct dryer air toward eyes or ears of people or pets.
- Never use dryer if it has damaged cord or plug, has been dropped, damaged or exposed to rain or water. Return to **Double K Industries** or Authorized Service Center for service.
- For use on animals only.
- For use by adults only. Use caution when working around children.
- Do not use attachments not recommended by **Double K Industries**.
- Operate only with filters in place. Keep filters clean, as dirty filters limit air intake and may damage the motor or cause overheating.
- Plug only into a properly grounded receptacle. Always make sure the amperage of the electrical outlet is sufficient for the amperage of the product. (See front of manual for amperage rating of this product).
- Do not use this product for anything other than its intended use.
- Do not attempt to perform any service or maintenance not outlined in this manual.
- Do not attempt product modifications or alterations. Do not use, if any parts or switches are damaged. Send to an Authorized Service Center or **Double K Industries** for service.
- When servicing, use only **Double K Industries** parts.



**A NOTE ABOUT HEAT:** Your Challengair 850/850-XL dryer has no heating element. The Challengair produces heat by a "flow-thru" motor system, meaning the air is pushed through the motors and is warmed by the natural heat of the motors that occurs during use. This means greater electrical savings and efficiency for you. The dryer will reach maximum temperature after about 3-5 minutes of use. Obviously, the greater the ambient temperature, the warmer the air from the dryer.

## STAND MODEL ASSEMBLY

Your dryer is packaged in two boxes. Your boxes include: **Box 1:** The dryer body. **Box 2:** Stand base with casters, Y-Bar, stand assembly, two 6' twist-on hoses, one arm extension, one air diffuser, 1 Airgonomic® Nozzle System kit and 2 hose ends. To assemble your dryer, first attach the Y of the Y-bar between the washers on the knob post. The Y-bar slot has a slight angle to it and should be positioned pointing toward the front of the dryer. Make sure the electrical cord exits toward the back of the dryer and the back of the Y-bar. Re-tighten knobs to hold dryer at desired angle. Attach the arm extension to the dryer body by loosening the finger nuts around the upper air outlet on the dryer body. Align the holes in the arm extension with the bolts in the dryer face. Tighten finger nuts securely.

### Assembly of Stand

The stand tube assembly is pre-assembled and wrapped in paper. The stand tube assembly is compressed and held in position by the center clamp. Loosen the handle on the clamp and allow the spring to extend the tube assembly. Place the end of the larger outer tube down into the center of the stand base. Twist and push down firmly. Lift the dryer head assembly, and position over the assembled stand and slide the tube of the Y-bar into the upper stand tube. With clamping handle still loose, raise or lower dryer to desired height and tighten stand adjustment handle as explained in the next paragraph.

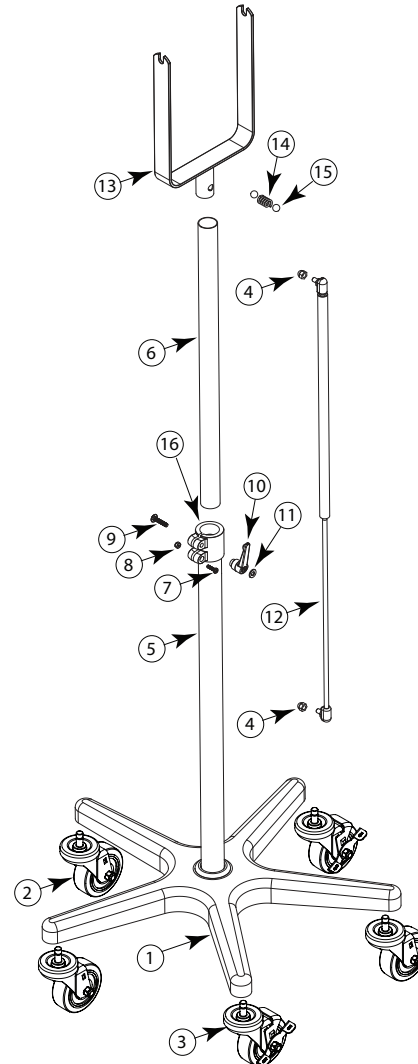

### Stand Height Adjustment and Dryer Angle Adjustment:

Your dryer has a "ratchet" type adjustment handle on the stand. To tighten the adjustment handle, turn the handle clockwise. As necessary, for additional tightening, pull the handle out to disengage the "ratchet" and while keeping the handle pulled out, turn the handle counter-clockwise to a suitable position for continued tightening. Release the handle to engage the "ratchet" again and repeat these procedures until the adjustment handle is tight. Reverse the turning direction of these actions to loosen the adjustment handle. **NOZZLE:** The nozzle at the end of the extension arm may be rotated to change the direction of the airflow. Simply rotate nozzle to the desired direction.

### PORTABLE MODEL

Your portable 850 includes: 2 - 8' twist-on hoses, 1 air diffuser, 1 Airgonomic Nozzle System kit and 2 hose ends.

### PARTS LIST - STAND ASSEMBLY

ITEM NO.	PART NUMBER	DESCRIPTION	QTY.
1	9023	STAND BASE 25" 5-LEG	1
2	7064	CASTER 3.5" RUBBER WHEEL	3
3	7063	CASTER LOCKING 3.5" RUBBER WHEEL	2
4	808	NUT ACORN 5/16-18 UNC ZINC PLATED	2
5	9020	TUBE 1-5/8 OD X 30" LONG .049 WALL	1
6	838	TUBE 1-3/8 OD X 241" LONG .049 WALL	1
7	7019	SCREW #10-32 X 3/4 PHP	1
8	5531	NUT #10 UNF NYLON INSERT	1
9	7015	BOLT CARRIAGE 1/4-20 X 1-1/4 LONG	1
10	7033	HANDLE LEVER ADJUSTABLE 1/4-20 UNC	1
11	10031	WASHER 1/4 SAE FLAT PLATED	1
12	830-1	SPRING GAS 36" LIFT-O-MAT	1
13	887	MOUNTING FORK 850 Y-BAR	1
14	7048	SPRING COMPRESSION	1
15	7047	BALL 1/2" CHROMED STEEL	2
16	7003	CLAMP TUBE STAND ADJUSTMENT SLEEVE	1

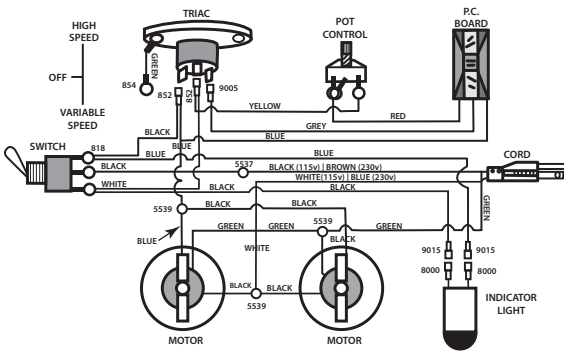

WIRING DIAGRAM - VARIABLE SPEED

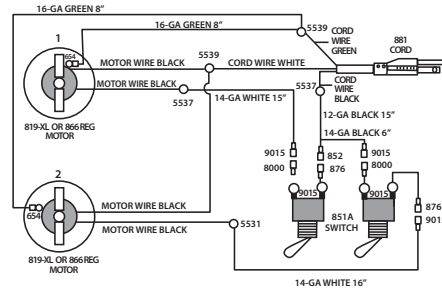

WIRING DIAGRAM - STANDARD SPEED

**MAINTENANCE - Brushes**

Your 850/850-XL dryer has 2 brush-type motors. The brushes should be checked for wear after approximately 600 hours of use. If the carbon brush is worn shorter than 1/4", the brushes should be replaced. Brushes may be ordered from **Double K Industries** or an Authorized Service Center. Please be sure to specify whether your dryer is an 850 or 850-XL as the brushes are slightly different.

**To Check and/or Replace Brushes:** (a) Unplug electrical cord from wall outlet. (b) Detach dryer faceplate by loosening the fastening screws. (Fig. 1) . (c) Remove front faceplate and set aside (motors and brushes are now visible and accessible). (Fig. 2) . (d) Find the flag connector on the top of the brush assembly. There is a wire leading to this connector. (e) Place a flathead screwdriver with a fine tip between the flag connector and the plastic brush housing. (f) Twist the screwdriver back and forth and gently wedge the flag connector out of the brush assembly. (g) Loosen the two brush assembly retainer bracket screws. (h) Remove the brush assembly. (i) Replace the brush assembly with the new one, making sure that the small tab on the bottom is fitted onto the corresponding slot on the motor frame. (j) Replace the brush assembly retainer bracket and tighten the screws which hold it in place. (k) Attach the flag connector to the top of the new brush in the same position as the previous brush. (l) Repeat these steps for the brush on the other side of the motor.

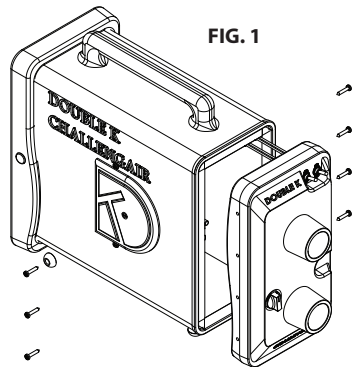

FIG. 1

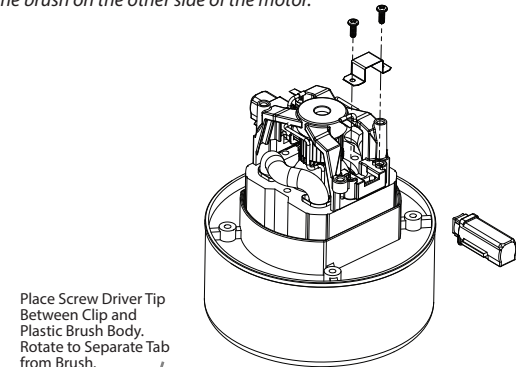
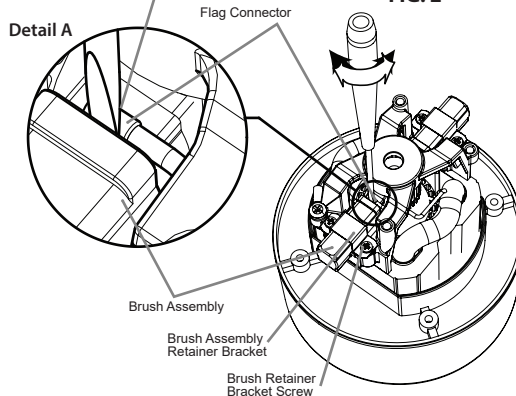

FIG. 2



**OPERATION - SWITCHES AND CONTROLS:**

- Standard Speed** - The standard two-speed unit has two toggle switches. Each switch operates one of the two motors in your dryer. You may use just one motor for low air or turn on both switches for high air volume. "ON" is in the up position and "OFF" is down.
- Variable Speed** - This unit has a dial speed control and a three-position toggle switch. The top position is High Speed, center position is OFF and the bottom position activates Variable Speed. In Variable Speed mode the indicator light will turn on and you can control the amount of air volume by turning the Variable Speed control knob.

**To Control Lower Air Outlet:** Turn the black control knob counter-clockwise to close the lower outlet and clockwise to open the outlet.

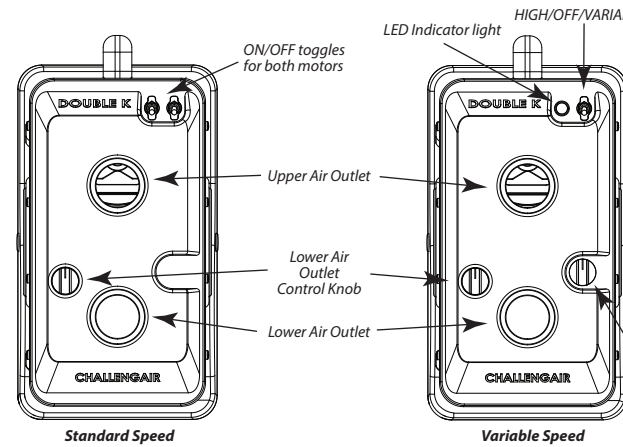

\*NOTE: The upper outlet is open at all times.  
 \*\*NOTE: Stand Dryers Only... If you wish to do only hose drying with the highest possible air flow, the arm extension on the upper air outlet may be removed by loosening the black thumb nuts at the base of the arm. A hose may then be used in the upper air outlet with the bottom outlet turned off.

**Filter Cleaning**

The filters of the 850/850-XL **Challengair** Forced Air Dryer should be kept clean. If the filters become heavily coated with hair and/or dirt, the air output of your dryer could be reduced and motor damage could occur. Never operate the dryer without filters in place.

**To clean the internal filters:** (a) Unplug dryer. (b) Remove the caps and fastening screws from the dryer back plate. (c) Remove the dryer back plate and set aside. (d) Remove individual motor filter discs on the back of each motor by pulling filter off motor. (See fig.4) (e) Clean motor filter discs by vacuuming off hair and dirt or wash filters gently in cool water and allow to air dry completely. (f) Replace filter discs on motor by pushing in to snap in place. (g) Replace dryer back plate and fastening screws and caps securely.

Any maintenance or service not explained in this manual should be performed by **Double K Industries** or an authorized service center. Call **Double K Industries** for the name of the service center nearest you. All warranty service must be performed by an Authorized Service Center to protect your warranty status.

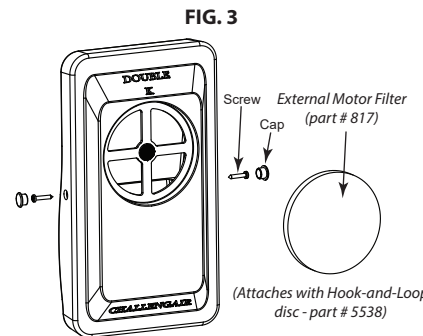

FIG. 3

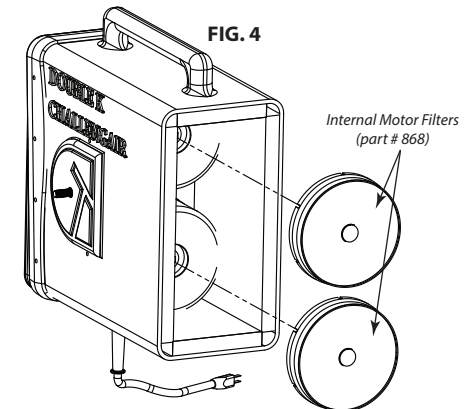
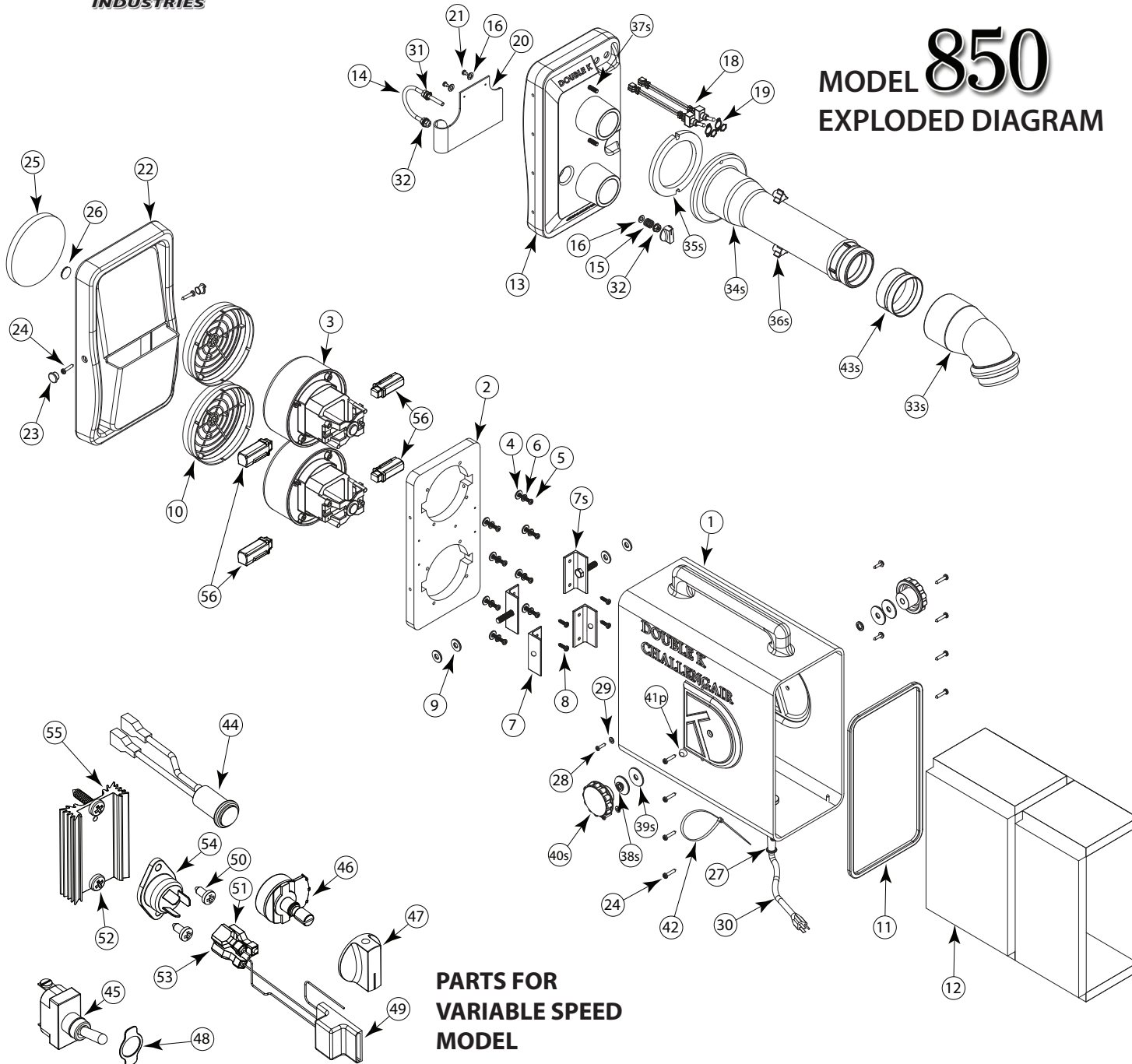

FIG. 4

**PARTS LIST**

"P" denotes Portable "S" denotes Stand Model

**MODEL 850**  
**EXPLODED DIAGRAM**



**PARTS FOR  
 VARIABLE SPEED  
 MODEL**

Item#	Part#	Description	Qty.
1	812 (P,S)	850 MOTOR HOUSING	1
2	855	MOTOR MOUNT 850	1
3	886	850 MOTOR 120v 60Hz - Regular Motor	2
	819T	850XL MOTOR UNIVERSAL SINGLE STAGE 120v	
	823	850XL MOTOR UNIVERSAL SINGLE STAGE 230v w/CHOKE	
4	10031	WASHER 1/4 SAE FLAT PLTD	9(8P)
5	832	SCREW #10-32X3/4 SMS	8
6	967	WASHER 1/4 INCH SPLIT LOCK	8
7	882	ANGLE 1/8 X 1-1/4 X 1-1/4 STEEL	2
8	5514	SCREW 10-24 X 3/4 SMS	4
9	846	WASHER 5/16 USS FLAT PLATED	4
10	868	INTAKE AIR FILTER	2
11	813A	GASKET 31" 850 FRONT HOUSING	1
12	840	FOAM, 850 SOUND PROOFING KIT	1
13	888AS	850 FACE PLATE, STAND	1
	888A	850 FACE PLATE PORTABLE	
14	847	UBOLT 1/4-20 2.0 ID	1
15	841	STEEL COMPRESSION SPRING	1
16	842	WASHER #10 USS FLAT	3
17	5509	KNOB SWITCH BLACK	2
18	851A	SWITCH TOGGLE 2-POS 20A 125V, (SW ONLY 851)	1
19	523	FACE PLATE ON/OFF	2
20	898	NEOPRENE COVER	1
21	443	MODIFIED SCREW #8 X 3/8 SHT METAL PHP	2
22	800	850 BACKPLATE	1
23	413	855 HOUSING PLUG	2
24	5514	SCREW 10-24 X 1 SMS	6
25	817	FILTER INTAKE 5.8 DIA.	1
26	5538	VELCRO, MVA 8 BLACK VELSTICK	1
27	571	CORD RELIEF PROTECTOR	1
28	843	SCREW #8 X 3/4 SHT METAL PHP	5
29	9028	WASHER #8 SAE FLAT PLATED	4
30	881-1	ASSY CORDSET W/TIE 120V 14 FT	1
31	835	NUT 1/4-20 UNC KEPS LOCKING	1
32	5506	NUT 1/4-20 UNCHEX SERRATED FL	4
33S	890	ARM NOZZLE DIRECTIONAL	1
34S	892	ARM EXTENSION	1
35S	807	GASKET, ARM EXTENSION	1
36S	555	KNOB 3-ARM BLK 1/4-20 UNC 2B	2
37S	801	SCREW 1/4-20 X 7/8 HH	1
38S	803	SCREW 1/4-20 X 7/8 HH	2
39S	899	WASHER 1.37 OD X .375 X .95T	4
40S	849	KNOB ROUND FLUTED RIM 38-16	2
41P	893	RUBBER FOOT	4
42	877	QUICK TIWRAP	2
43S	7046A	ARM EXTENSION SLEEVE	1
44	834	LIGHT INDICATOR 125V, 1/3 WATT	1
45	814	SWITCH TOGGLE 3-POS 20A 125V	1
46	634	RHEOSTAT, SPEED CONTROL 850	1
47	5509	KNOB SWITCH BLACK	1
48	523	FACE PLATE BLANK SIDE	1
49	641	PCB W/CONNECTOR	1
50	845	SCREW #8 X 3/8 SHT METAL PHP	2
51	852	TERMINAL 1/4 12-1 GA, F	2
52	843	SCREW 10-24 X 3/4 SMS	2
53	9015	TERMINAL 1/4 16-14 GA, F	5
54	640	TRIAC	1
55	2041	HEAT SYNC	1
56	883	850 MOTOR BRUSH (regular)	4
	815	850XL MOTOR BRUSH	
	880	850XL 230v MOTOR BRUSH	